

Absperrventil PN 16

**Eckform, Sphäroguss/Rg + SoMs
 oder als absperrbares Rückschlagventil (AW 315)
 mit Stopfbuchspackung aus Reingraphit**

- Flanschbohrungen nach DIN PN 16
- Baulänge nach DIN EN 558-1 (DIN 3202-F1)
- Ausführung nach DIN 86251/86252, Kennz. 02

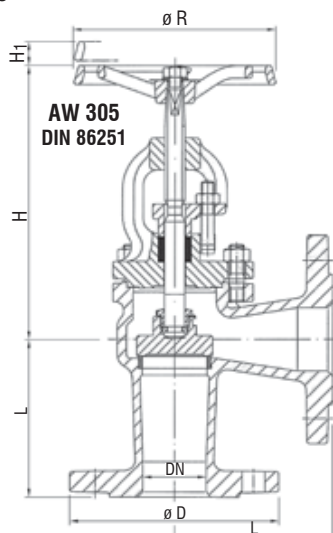

Globe Valve PN 16

**angle pattern, nodular cast iron/Rg + SoMs
 or as screw down non return valve (AW 315)
 with gland packing out of pure graphite**

- flange drilling acc. to DIN PN 16
- face to face acc. to DIN EN 558-1 (DIN 3202-F1)
- design acc. to DIN 86251/86252, code no. 02

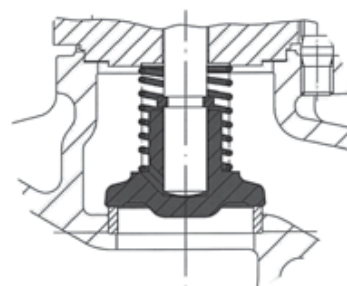

**AW 315
 DIN 86252**
 loser Kegel als absperrbares Rückschlagventil
 loose disc as screw down non return valve

AW-Nr. AW no.	Pos. item	Bezeichnung denomination	Werkstoff material	nach DIN EN acc. to DIN EN	Werkstoff-Nr. material no.
305 315	1	Gehäuse / body	Sphäroguss / nodular cast iron	EN-GJS-400-18U-LT	EN-JS1049
	2	Bügeldeckel / bonnet	Sphäroguss / nodular cast iron	EN-GJS-400-18U-LT	EN-JS1049
	3*	Kegel / disc	Rotguss / gunmetal	CuSn5Zn5Pb5-C	CC491K
	4*	Spindel / stem	Sondermessing / special brass	CuZn35Ni3Mn2AlPb	CW710R
	5*	Sitzring / seat ring	Rotguss / gunmetal	CuSn5Zn5Pb5-C	CC491K
	6	Flachdichtung / gasket	Reingraphit mit CrNi Stahlfolien-Einlage pure graphite CrNi laminated		
	7	Handrad / handwheel	Grauguss, beschichtet / cast iron, coated	EN-GJL-250	EN-JL-1040

* Wir behalten uns vor, höherwertige Werkstoffe bzw. zinkfreie Bronze einzusetzen.
 We reserve the possibility to use materials of a higher grade respectively zincfree bronze.

DN	L	H	H ₁	R	D	≈ kg
15	90	185	9	120	95	4,0
20	95	185	9	120	105	4,5
25	100	200	13	140	115	5,6
32	105	200	13	140	140	6,6
40	115	215	21	160	150	9,2
50	125	215	19	160	165	11,6
65	145	245	28	180	185	17,0
80	155	280	32	200	200	22,6
100	175	320	36	225	220	33,0
125	200	360	52	250	250	46,0
150	225	415	56	400	285	68,0
200	275	495	73	520	340	100,0
250	325	575	80	520	405	204,0
300	375	655	110	520	460	270,0
350	425	735	116	640	520	398,0
400	475	740	126	640	580	570,0
500	525	840	181	640	715	885,0

Auf Anfrage / on request

- Regulierkegel
regulating disc
- Stellungsanzeige
position indicator

als Seeventil geeignet / suited as sea-valve

Druck-Temperatur-Zuordnung / pressure-temperature-rating	
-10°C bis / up to 120°C	16 bar
150°C	15,5 bar

Temperatur / temperature	max. +180°C
--------------------------	-------------

Maße und Gewichte können je nach Hersteller abweichen / depending on manufacturers measures and weight can change