

Absperrventil PN 25/40

Durchgangsform, Stahlguss/Rg + SoMs
 oder als absperrbares Rückschlagventil (AW 316)
 mit Stopfbuchspackung aus Reingraphit

- Flanschbohrungen nach DIN PN 25/40
- Baulänge nach DIN EN 558-1 (DIN 3202-F1)
- Ausführung nach DIN 86251/86252, Kennz. 02

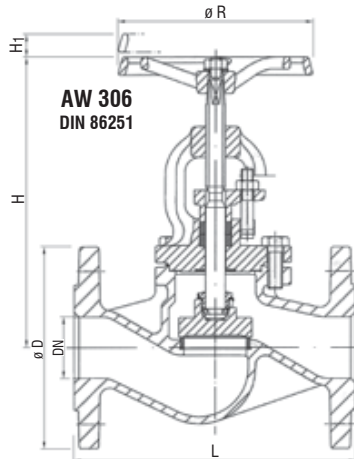

Globe Valve PN 25/40

straight pattern, cast steel/Rg + SoMs
 or as screw down non return valve (AW 316)
 with gland packing out of pure graphite

- flange drilling acc. to DIN PN 25/40
- face to face acc. to DIN EN 558-1 (DIN 3202-F1)
- design acc. to DIN 86251/86252, code no. 02

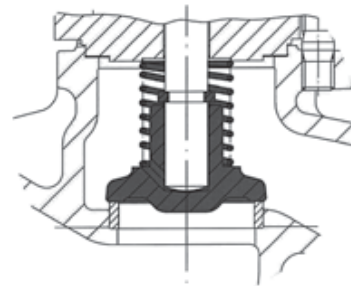

AW 316
 DIN 86252

loser Kegel als absperrbares Rückschlagventil
 loose disc as screw down non return valve

AW-Nr. AW no.	Pos. item	Bezeichnung denomination	Werkstoff material	nach DIN EN acc. to DIN EN	Werkstoff-Nr. material no.
306 316	1	Gehäuse / body	Stahlguss / cast steel	GP240GH+N	1.0619+N
	2	Bügeldeckel / bonnet	Stahlguss / cast steel	GP240GH+N	1.0619+N
	3*	Kegel / disc	Rotguss / gunmetal	CuSn5Zn5Pb5-C	CC491K
	4*	Spindel / stem	Sondermessing / special brass	CuZn35Ni3Mn2AlPb	CW710R
	5*	Sitzring / seat ring	Rotguss / gunmetal	CuSn5Zn5Pb5-C	CC491K
	6	Flachdichtung / gasket	Reingraphit mit CrNi Stahlfolien-Einlage pure graphite CrNi laminated		
	7	Handrad / handwheel	Grauguss, beschichtet / cast iron, coated	EN-GJL-250	EN-JL-1040

* Wir behalten uns vor, höherwertige Werkstoffe bzw. zinkfreie Bronze einzusetzen.
 We reserve the possibility to use materials of a higher grade respectively zincfree bronze.

DN	L	H	H ₁	R	PN 25		PN 40	
					D	≈ kg	D	≈ kg
15	130	185	9	120	95	4,4	95	4,8
20	150	185	9	120	105	5,4	105	5,4
25	160	205	13	140	115	6,3	115	7,1
32	180	205	13	140	140	7,0	140	8,0
40	200	230	21	160	150	10,5	150	11,5
50	230	230	19	160	165	13,8	165	13,5
65	290	270	28	180	185	21,0	185	23,5
80	310	305	32	200	200	27,5	200	28,0
100	350	355	36	225	235	40,0	235	39,5
125	400	395	52	250	270	61,0	270	61,0
150	480	450	56	400	300	84,0	300	84,0
200	600	570	73	520	360	160,0	375	170,0
250	730	685	80	520	425	265,0	450	283,0
300	850	770	110	520	485	377,0	515	414,0
350	980	860	116	640	555	510,0	580	557,0
400	1100	865	126	640	620	780,0	660	857,0
500	1350	995	181	640	730	1095,0	755	1150,0

Auf Anfrage / on request

- Regulierkegel
regulating disc
- Stellungsanzeige
position indicator

als Seeventil geeignet / suited as sea-valve

Druck-Temperatur-Zuordnung / pressure-temperature-rating		
	PN 25	PN 40
-60°C bis / up to -10°C	18,7 bar	30 bar
-10°C bis / up to 120°C	25 bar	40 bar
150°C	23,9 bar	38,1 bar

Temperatur / temperature	max. +180°C
--------------------------	-------------

Maße und Gewichte können je nach Hersteller abweichen / depending on manufacturers measures and weight can change