

Zwischenflansch- Rückschlagklappe PN 10/16

Stahl/Stahl

Sandwich Swing Check Valve PN 10/16

steel/steel

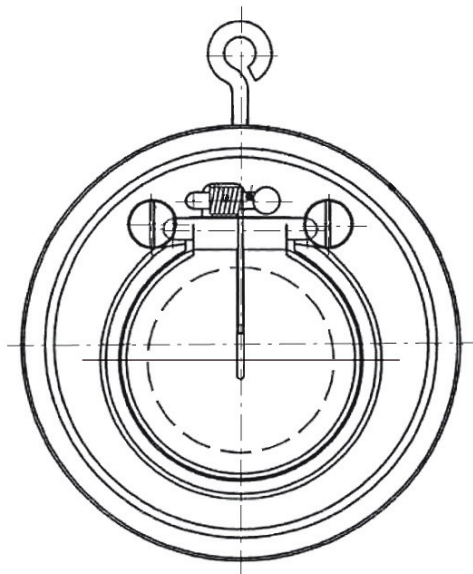
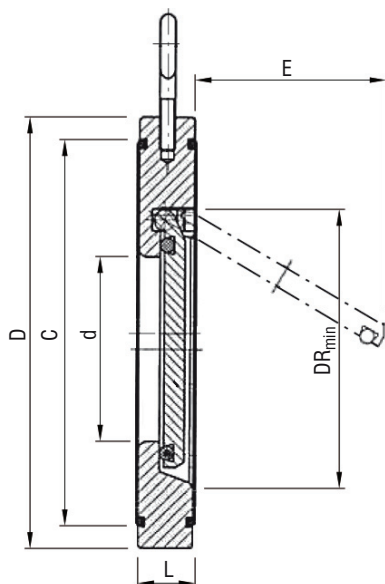

AW-Nr. AW no.	Pos. item	Bezeichnung denomination	Werkstoff material	nach DIN EN acc. to DIN EN	Werkstoff-Nr. material no.
199-St	1	Scheibe / body	Stahl, galv. / steel, galvanized	P250GH	1.0460
	2	Klappe / flap	Stahlguss, galv. / cast steel, galv.	GP240GH	1.0619
	3	O-ring / o-ring	NBR / FPM / EPDM / PTFE / metallisch dichtend / metal seated		

DN	Ø D		L	Ø d	C	DR _{min}	E	≈ kg
	PN 10	PN 16						
32	85	85	15	18	59	37	22	0,5
40	95	95	16	22	72	43	25	0,8
50	109	109	14	32	86	54	37	1
65	129	129	14	40	109	70	50	1,4
80	144	144	14	54	119	82	61	1,8
100	164	164	18	70	146	106	77	2,9
125	195	195	18	92	173	131	98	3,9
150	220	220	20	112	197	159	120	4,5
200	275	275	22	154	255	207	160	7,5
250	330	331	26	192	312	260	190	13
300	380	386	32	227	363	309	220	23
350	440	446	38	266	416	341	250	33,5
400	491	499	44	310	467	392	290	52
450	541	558	52	350	520	442	340	71
500	596	621	58	400	550	493	390	94
600	698	738	62	486	660	595	470	128

Verwendungsbereich:

Für gasförmige und flüssige Medien,
in Öl-, Luft-, Gas- und Wassersystemen

Application:

for gaseous or liquid media,
in oil-, air-, gas- and water systems

auf Anfrage / on request:

- andere Werkstoff-Kombinationen
other material-combinations
- mit Rückstellfeder
with reset spring

Temperaturbereiche / temperature ranges	
NBR	-10°C bis / up to +90°C
EPDM	-10°C bis / up to +120°C
FPM	-10°C bis / up to +150°C
PTFE	-10°C bis / up to +200°C
metallisch / metal	-10°C bis / up to +300°C